



Industrial Unit Heater

Extensive selection of models ranging from 3 to 50kW – each with spiral finned elements and sealed ball-bearing motors for long service life.

Features

- Built-in adjustable thermostat on models up to and including 12kW; field installed thermostat kit available for 15-50 kW unit heaters
- Ceiling hanger bracket included, optional wall bracket available (allows swivel movement)
- Five-way adjustable louvers to direct airflow
- EU models up to and including 12kW are UL and CSA approved for vertical and horizontal mounting

Applications

Shipping / Receiving Areas | Warehouse Storage Areas | Garages

Specifications

Voltage	- 120V, 208V, 240V, 277V, 347V, 480V, 600V - 1/3 phase
Wattage	- Three cabinet sizes available: EUH: 3-12kW, EUL: 15-30kW, EUS: 40-50kW
Color	- Almond
Finish	- Polyester/epoxy powder coating resists fading and abrasion
Construction	- Constructed of 18 gauge die formed steel - Units have individual adjustable 20 gauge convex profile air directing louvers - Louvers are friction fastened to a single piece 20 gauge frame to prevent movement, once adjusted to the desired position
Heating Element	- Includes metal tubular sheath fused with spiral steel fins - Contains a high quality nickel chromium wire, encased in solidly packed magnesium oxide insulation
Motor & Fan	- Fan size and pitch is matched to the power and speed of the unit to optimize CFM, airflow, temperature rise, and quietness - Motor is heavy duty, continuous operation, totally enclosed, thermally protected with permanently lubricated ball bearings
Controls	- Jumper provided to disable built-in thermostats when remote thermostats are required - Summer fan control and low voltage control options are field installed
Warranty	- 1-year warranty on complete unit

Dimensions

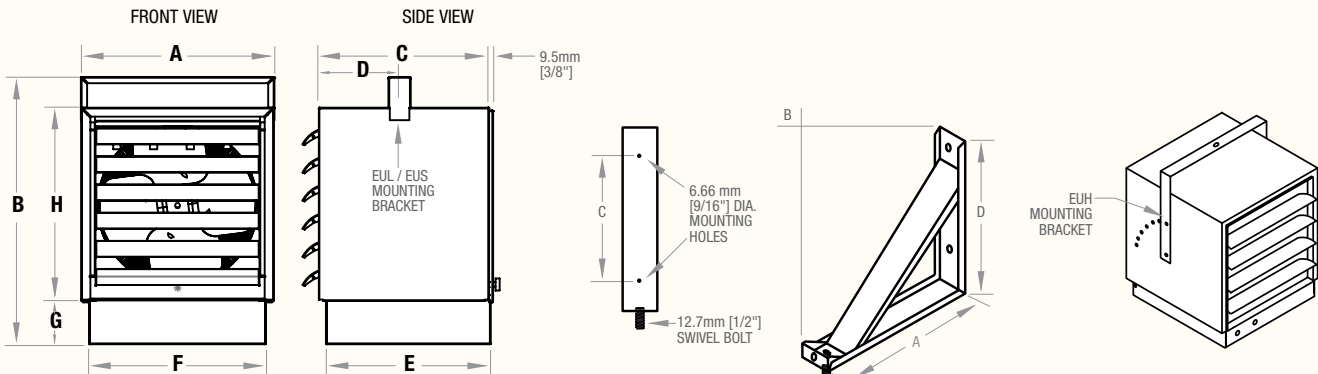

Model	A	B	C	D	E	F	G	H
EUH	330mm 13"	495mm 19-1/2"	330mm 13"	165mm 6-1/2"	318mm 12-1/2"	299mm 11-3/4"	64mm 2-1/2"	330mm 13"
EUL	502mm 19-3/4"	699mm 27-1/2"	419mm 16-1/2"	257mm 10-1/8"	410mm 16-1/8"	462mm 18-1/4"	118mm 4-5/8"	500mm 19-3/4"
EUS	578mm 22-3/4"	745mm 29-1/16"	645mm 25-3/8"	391mm 15-3/8"	633mm 25"	499mm 19-3/4"	130mm 5-1/8"	533mm 21"

Hanger Bracket				
Model	A	B	C	D
EUH	318mm 12-1/2"	356mm 14"	203mm 8"	279mm 11"
EUL	514mm 20-1/2"	533mm 21"	533mm 21"	654mm 25-3/4"
EUS	635mm 25"	654mm 25-3/4"	443mm 17-1/2"	533mm 21"

Ordering Guide

Cat. No.	kW	BTU	Volts	Phase	CFM	Weight (kg/lbs.)
EUH						
EUH02B21T	2	6824	208	1	350	16 / 36
EUH02B24CT	2	6824	208	1/3	350	16 / 36
EUH02B31T	2	6824	240	1	350	16 / 36
EUH02B51CT	2	6824	347	1	350	16 / 36
EUH02B71CT	2	6824	480	1	350	16 / 36
EUH02B74CT	2	6824	480	1/3	350	18 / 40
EUH02B81CT	2	6824	600	1	350	18 / 40
EUH02B84CT	2	6824	600	1/3	350	18 / 40
EUH03B11T	3	10236	120	1	350	16.0 / 36
EUH03B21T	3	10236	208	1	350	16.0 / 36
EUH03B24CT	3	10236	208	1/3	350	16.0 / 36
EUH03B31T	3 / 2.3	10236 / 7677	240 / 208	1	350	16.0 / 36
EUH03B34CT	3 / 2.3	10236 / 7677	240 / 208	1/3	350	16.0 / 36
EUH03B41T	3	10236	277	1	350	18.0 / 40
EUH03B51CT	3	10236	347	1	350	18.0 / 40
EUH03B73CT	3	10236	480	3	350	18.0 / 40
EUH03B81CT	3	10236	600	1	350	18.0 / 40
EUH03B83CT	3	10236	600	3	350	18.0 / 40
EUH04B21T	4	13648	208	1	350	16/36
EUH04B24CT	4	13648	208	1/3	350	16/36
EUH04B31T	4	13648	240	1	350	16/36
EUH04B51CT	4	13648	347	1	350	16/36
EUH04B71CT	4	13648	480	1	350	18/40
EUH04B74CT	4	13648	480	1/3	350	18/40
EUH04B81CT	4	13648	600	1	350	18/40
EUH04B83CT	4	13648	600	3	350	18/40
EUH05B21T	5	17060	208	1	350	16.0 / 36
EUH05B24CT	5	17060	208	1/3	350	16.0 / 36
EUH05B31T	5 / 3.8	17060 / 12795	240 / 208	1	350	16.0 / 36
EUH05B34CT	5 / 3.8	17060 / 12795	240 / 208	1/3	350	16.0 / 36
EUH05B41T	5	17060	277	1	350	18.0 / 40
EUH05B51CT	5	17060	347	1	350	18.0 / 40
EUH05B74CT	5	17060	480	1/3	350	18.0 / 40
EUH05B84CT	5	17060	600	1/3	350	18.0 / 40
EUH08B24CT	7.5	25590	208	1/3	600	21.0 / 46
EUH08B34CT	7.5 / 5.6	25590 / 19193	240 / 208	1/3	600	21.0 / 46
EUH08B74CT	7.5	25590	480	1/3	600	22.0 / 50
EUH08B84CT	7.5	25590	600	1/3	600	22.0 / 50
EUH10B24CT	10	34120	208	1/3	600	21.0 / 46
EUH10B34CT	10 / 7.5	34120 / 25590	240 / 208	1/3	600	21.0 / 46
EUH10B74CT	10	34120	480	1/3	600	22.0 / 50
EUH10B84CT	10	34120	600	1/3	600	22.0 / 50
EUH12B74CT	12	40944	480	1/3	600	22.0 / 50
EUH12B84CT	12	40944	600	1/3	600	22.0 / 50

Cat. No.	kW	BTU	Volts	Phase	CFM	Weight (kg/lbs.)
EUL						
EUL15B23C	15	51180	208	3	1200	45.0 / 100
EUL15B33C	15	51180	240	3	1200	48.6 / 108
EUL15B51C	15	51180	347	1	1200	48.6 / 108
EUL15B71C	15	51180	480	1	1200	48.6 / 108
EUL15B73C	15	51180	480	3	1200	48.6 / 108
EUL15B81C	15	51180	600	1	1200	48.6 / 108
EUL15B83C	15	51180	600	3	1200	48.6 / 108
EUL20B21C	20	68240	208	1	1200	45.0 / 100
EUL20B31C	20	68240	240	1	1200	48.6 / 108
EUL20B23C	20	68240	208	3	1200	45.0 / 100
EUL20B33C	20	68240	240	3	1200	48.6 / 108
EUL20B51C	20	68240	347	1	1200	48.6 / 108
EUL20B71C	20	68240	480	1	1200	48.6 / 108
EUL20B73C	20	68240	480	3	1200	48.6 / 108
EUL20B83C	20	68240	600	3	1200	48.6 / 108
EUL25B73C	25	85300	480	3	1200	48.6 / 108
EUL25B83C	25	85300	600	3	1200	48.6 / 108
EUL30B23C	30	102360	208	3	1600	58.1 / 129
EUL30B73C	30	102360	480	3	1600	58.1 / 129
EUL30B83C	30	102360	600	3	1600	58.1 / 129

EUS						
EUS40B73C	40	136480	480	3	1950	72.0 / 160
EUS40B83C	40	136480	600	3	1950	72.0 / 160
EUS50B73C	50	170600	480	3	1950	72.0 / 160
EUS50B83C	50	170600	600	3	1950	72.0 / 160

Note: T = Built-in thermostat, C = Built-in contactor,
 CT = Built-in thermostat and contactor.
 Units rated 20kW and higher are suitable for 2 stage operation

Built-in single pole thermostat controls are standard up to and including 12kW models. Units showing 1/3 phase are field convertible to desired phase. 208V units have 208V control voltage, 240V control on all others, except for EUS units which have 120V control. Transformers are provided where necessary.



Control Options (field installed)

Cat. No.	Description
EUAF2	Summer fan switch
EUAR11	24V low voltage relay/transformer kit for 120V unit heaters
EUAR21	24V low voltage relay/transformer kit for 208V unit heaters
EUAR31	24V low voltage relay/transformer kit for 240V unit heaters
EUARCR	24V low voltage relay less transformer, suitable for all units
EUAT	Single pole thermostat kit for 15-50kW unit heaters

Accessories (field installed)

Cat. No.	Description
EUD20J3	Power disconnect 3 phase, 20A / 600V
EUD30Y2	Power disconnect 2 phase, 30A / 277V
EUD30J3	Power disconnect 3 phase, 30A / 600V
EUD55J3	Power disconnect 3 phase, 55A / 600V
EUHWB	Wall hanger bracket for EUH series (3-12kW)
EULSWB	Wall hanger bracket for EUL/EUS series (15-50kW)